

**STEINER**

**LT245CF**

# 4.5 Tonne Hydraulic Clear Floor 2 Post Hoist



**HARD WORKING DIRECT DRIVE 2 POST FOR  
DEALERSHIPS AND BUSY WORKSHOPS**



## Ideal for:

Dealerships and busy workshops that need a reliable hoist.

## Features:

- › S-Column for extra strength and rigidity
- › Ezi-reach three stage asymmetrical arms
- › Simple one button push operating process
- › Electro-magnetic locks
- › High quality direct drive cylinders for powerful and safe lifting performance
- › Available in three phase and single phase
- › Padded overhead safety bar and door protection rubber pads to protect the vehicle
- › Height adaptors available as standard
- › Excellent 3900mm overall height

OUR PROMISE:  
**100**  
ONE HUNDRED DAYS  
100% SATISFACTION

If you are not 100% satisfied with your equipment, Treadway Equipped will repair, replace or refund the equipment free of charge within the first 100 days.

LT245CF

# 4.5 Tonne Hydraulic Clear Floor 2 Post Hoist

**STEINER**



## Features:

- › S-Column for extra strength and rigidity
- › Ezi-reach three stage asymmetrical arms
- › Simple one button push operating process
- › Electro-magnetic locks
- › High quality direct drive cylinders for powerful and safe lifting performance
- › Available in three phase and single phase
- › Padded overhead safety bar and door protection rubber pads to protect the vehicle
- › Height adaptors available as standard
- › Excellent 3900mm overall height

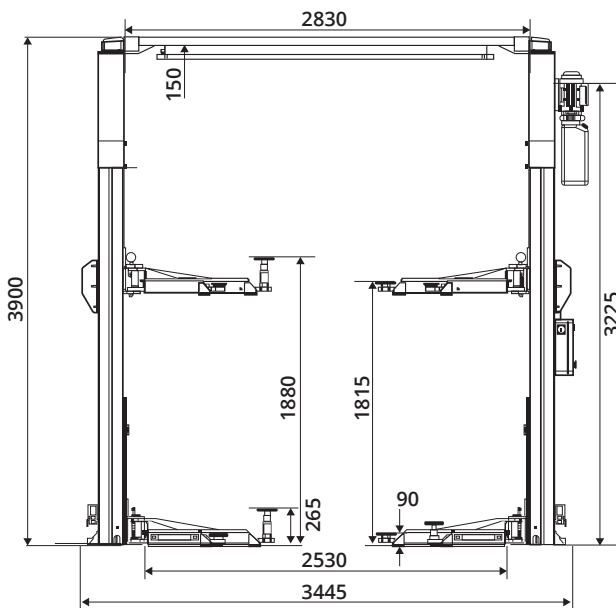

## SPECIFICATIONS

Load Capacity	4500kg
Overall Height	3900mm
Lifting height	1990mm
Min lifting Height	90mm
Lifting time	45 sec
Overall Width	3445mm
Width between Columns	2830mm

LT245CF

## 4.5 Tonne Hydraulic Clear Floor 2 Post Hoist

Hard working Direct Drive 2 Post for Dealerships and busy Workshops

### Design & safety

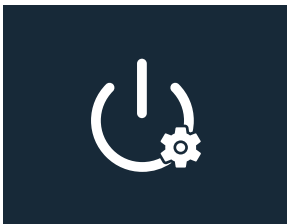

- › **Safety**  
Automatic shut-off system prevents damage to the top of vehicles.



- › **Top travel limit switch**  
Helps safely lift vehicles minimising the risk of hitting the top bar.



- › **Lifting arm resistance system**  
Makes sure the arms are locked securely.



- › **Control box**  
Simple one button operations.



- › **Adjustable screw pads**  
Provide flexible and secure lifts.



- › **Design**  
S-Column for extra strength and rigidity



OUR PROMISE:

**100**

ONE HUNDRED DAYS  
100% SATISFACTION

If you are not 100% satisfied with your equipment, Treadway Equipped will repair, replace or refund the equipment free of charge within the first 100 days.

**0800 436 436**  
[treadwayequipped.co.nz](http://treadwayequipped.co.nz)